

Frame Tent Parts List

Tents by Ohenry Productions last a lifetime!

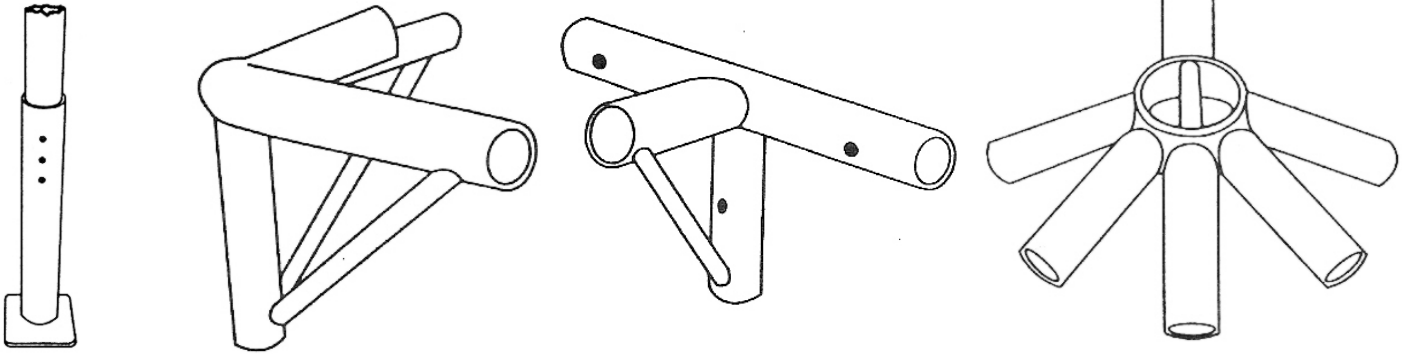
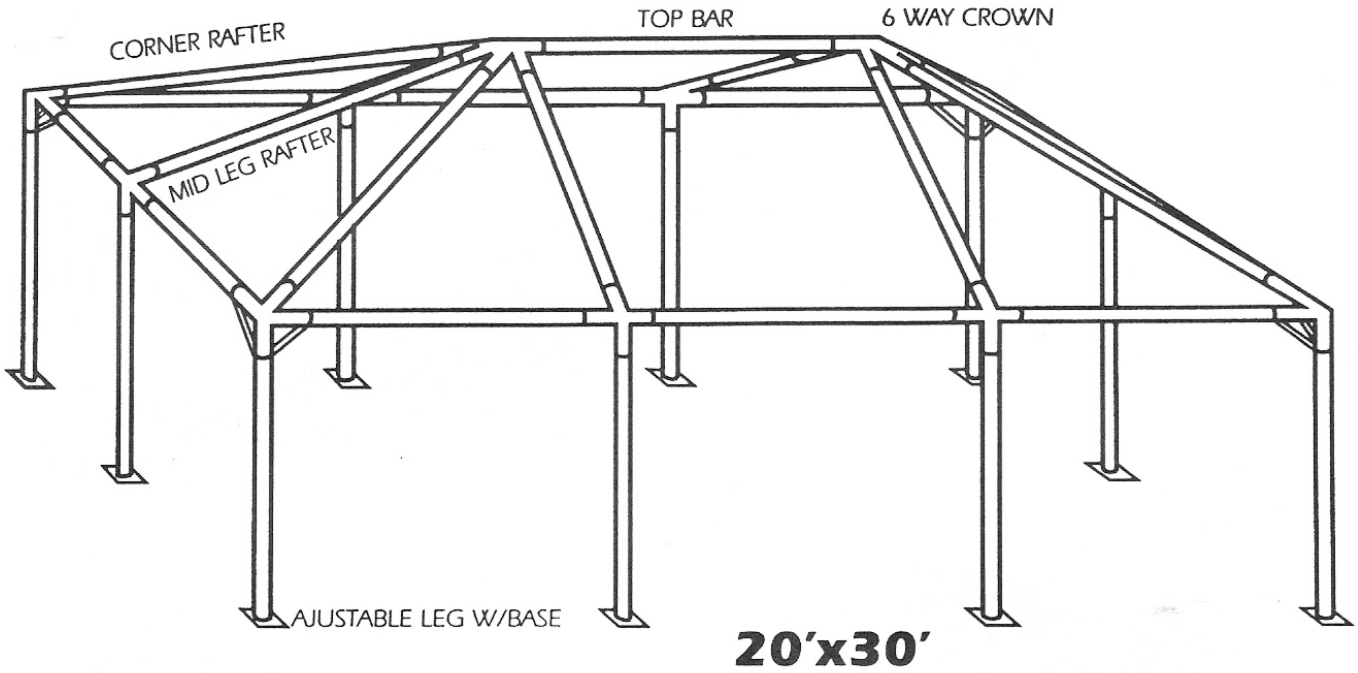

A. ADJUSTABLE LEG WITH BASE

B. CORNER FITTING

C. MID-LEG/RAFTER FITTING

D. 6 WAY CROWN

8' ADJUSTABLE LEGS W/BASEPLATE	10	9' 5" TOP BAR	1
14' 5" CORNER RAFTER	4	CORNER FITTING	4
10' 5-1/2" MID RAFTER	6	MID LEG/RAFTER FITTING	6
9' 5" SIDE BAR	10	6 WAY CROWN	2

“ALUMINUM CLASSIC”

ASSEMBLY INSTRUCTIONS

All tubing is labeled for easy Identification.

Please verify the parts with the chart provided before you begin assembly.

Assembly steps:

1. Place the Side bars in a square on a flat surface.
2. Place one Corner fitting in each corner.
3. For tents over 15' place the Mid-leg/rafter fittings between Side bars at 10' intervals.
4. Slide the Side bars into the Corner fittings until the snap buttons engage. Then attach the Side bars to the Mid-leg/rafter fittings. Be sure the snap buttons engage.

The perimeter of your unit is now assembled.

5. Slide a Corner rafter into each Corner fitting until the snap buttons engage.
6. Install the Top fitting on the Corner rafters in opposite pairs.
(IMPORTANT: Be sure the slightly shorter fitting stubs are pointed toward the corners. The slightly longer stubs on the Top fittings align with the Mid-leg/rafter fittings.)
7. For tents over 15' slide a Mid rafter into the Top fitting first then into the corresponding Mid-leg/rafter fitting. The perimeter of the frame is designed to flex sufficiently to make this step easy. Repeat this step for each remaining Mid-rafter. Remember to work in opposite pairs.

The upper structure is now complete.

(It is recommended two persons be available when lifting the frame to install the legs.)

8. Place the cover on the frame. Be sure to center the cover while the upper structure is still on the ground.
9. Lift one side of the tent and attach two adjustable legs (with base plates) in their lowest position in each corner. Repeat for the other side. Then attach (if applicable) the remaining legs in each Mid-leg/rafter fitting, also in the lowest position.
10. Before raising legs to the desired height, secure the cover using the snap buckles. Start by securing one corner and then the opposite corner. Once the corners are secure, tighten the snap buckles by the Mid-leg/rafter fittings. The rest of the snap buckles should be tightened until the cover is firmly and evenly attached to the frame.

Over-tightening the straps can cause unsightly wrinkling.

11. Raise the frame to desired height until the snap buttons engage.
12. While this unit will stand on its own, it is **NOT** intended that the base plates be used as an anchoring method.
It is imperative the tent be secured with ropes and stakes or any other appropriate anchoring method. It is recommended that you do not bolt the base plates to any surface.

Store the cover only when clean and dry.

In the event of high winds, the cover should be removed.

Rev. 01/25/95